

035126

REVISION RECORD			
ECN NO	CUSTOMER REV	AAVD REV	DATE
11779	E	A	2-12-01

PART TABLE			
ITEM	DESCRIPTION	MAT'L	QTY.
035119 (1)	BODY (15116-1)	SEE	1
035125 (2)	COLLECTOR PLATE (15982-1)	NOTE	1
035124 (3)	CONTACTS (15981)		2

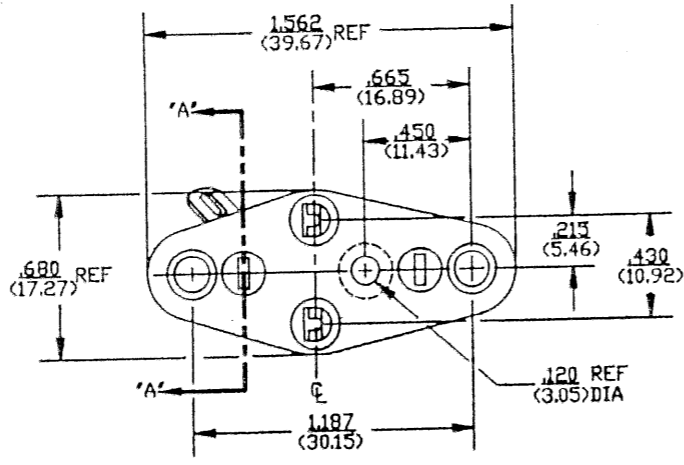

- NOTES:
- D.C. CURRENT RATING: 5 AMPS, CONTINUOUS DUTY - 15 AMPS PEAK.
 - CONTACT RESISTANCE: AFTER 3 INSERTIONS OF A $.043 \pm .0001$ DIA PIN CONTACT RESISTANCE WITH A $.038 \pm .0001$ DIA PIN INSERTED SHALL NOT EXCEED .0075 OHMS AT 5 AMPS.
 - INSERTION FORCE: THE FORCE REQUIRED TO INSERT A $.043 \pm .0001$ DIA PIN SHALL NOT EXCEED 5 LBS.
 - CONTACT RETENTION: AFTER 3 INSERTIONS OF A $.043 \pm .0001$ DIA PIN, THE CONTACT MUST BE ABLE TO RETAIN A 3 OUNCE PIN OF $.038 \pm .0001$ DIA.
 - TEST PINS: SHALL BE OF HARDENED STEEL WITH CHAMFERED TIP.
 - DELETED
 - MATERIAL:

ITEM NO. 1, BODY: THERMOPLASTIC POLYESTER 30% GLASS FILLED PER MIL-M-24519 TYPE GPT-30F WITH U.L. TEMPERATURE INDEX OF 130°C OR BETTER AND FLAMMABILITY RATING 94 V-0. COLOR - BLACK (15116-1) FOR 6-32 UNC-2B THREADS

ITEM NO. 2, COLLECTOR PLATE: BRASS WITH TIN PLATE.
ITEM NO. 3, CONTACTS: PHOSPHOROUS BRONZE .012(.30) THICK WITH TIN PLATE.

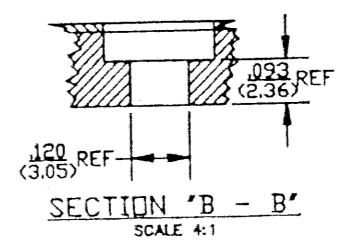
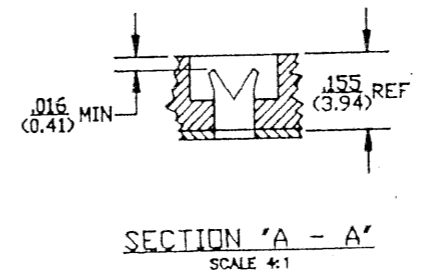
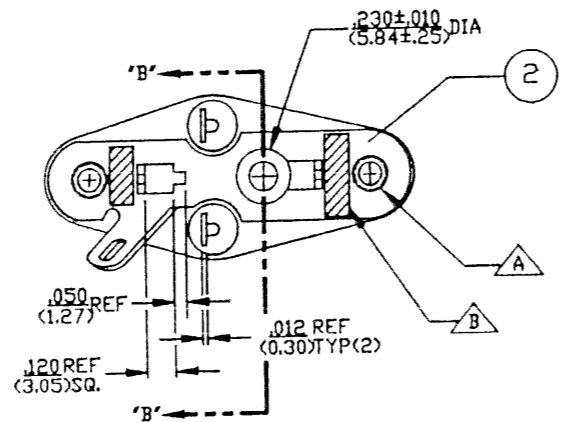
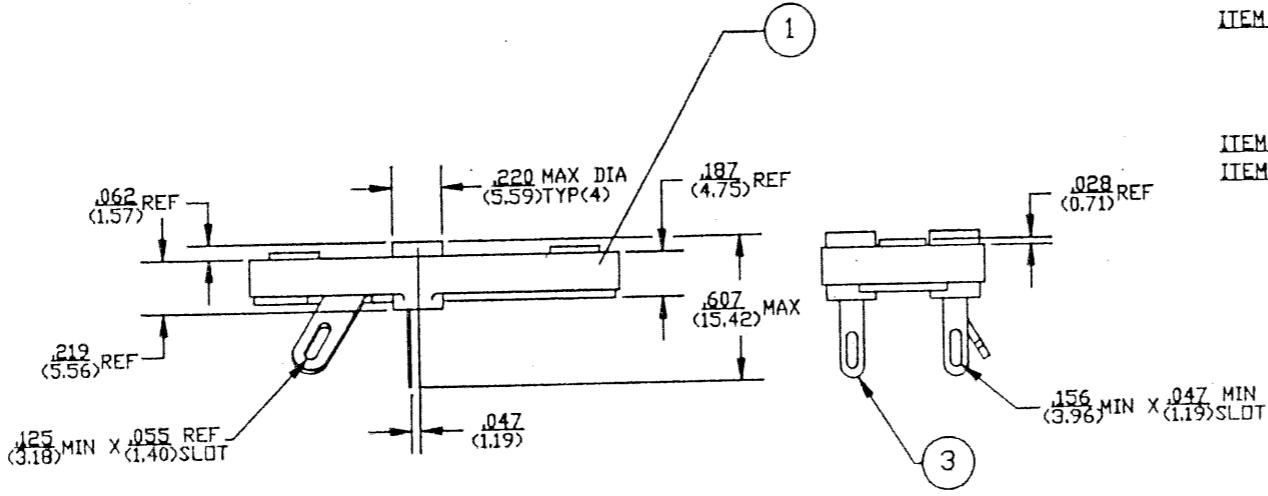

035126

E	ADD -3 PART	3/17/92	901777	C.H.D.	D.L.B	TOLERANCES: $\pm .016(.41) \pm 1'$ EXCEPT AS NOTED	NOTE: METRIC DIMENSIONS ARE IN PARENTHESES AND ARE EXPRESSED IN MILLIMETERS.
LEVEL	REVISION RECORD	DATE	ECN	DRAWN	CHECKED	MATERIAL: SEE NOTE	Thermalloy Inc. TITLE: SOCKET, TO-3 POWER SINGLE LUG ORIGINATING ECN: 3408 SIZE: C DRAWING NUMBER: 16356-1 SCALE: 2:1 REVISION: E
PROPRIETARY INFORMATION THIS DOCUMENT CONTAINS PROPRIETARY AND/OR PATENT INFORMATION AND IS NOT TO BE REPRODUCED IN WHOLE OR PART WITHOUT WRITTEN AUTHORIZATION BY THERMALLOY, INC. EXCEPT PREPARING SOURCING INFORMATION SPECIFICATIONS FOR THERMALLOY, INC. PRODUCTS.						CODE IDENTIFICATION NUMBER 13103	
DRAWN: J.RUVANG DATE: 6/30/82		CHECKED: D.BLAND DATE: 7/2/82		APPROVED: D.BLAND DATE: 7/2/82			

16356